



**THE ROOST**  
MERTHYR TYDFIL

# **CROESO, WELCOME TO THE ROOST**

This pack includes information about the cabin, site and how everything works plus area info - walks, rides, how to get to BPW by bike, shopping, eating, things to do, see etc.

We'd love to see your Roost pics on social media and we'd welcome any feedback and suggestions.

Tag/follow @roostmerthyr on Instagram, Facebook and Twitter

Have a lush stay!

---

**If you need anything else, contact us:**

**07484 697392**

**hello@roostmerthyr.co.uk**

# CONTENTS

---

	Page
1. Welcome to the Roost	1
2. Sustainability at the Roost	2
3. Roost site map	4
4. Facilities	4
5. Any problems/in case of emergency	5
6. WiFi	5
7. Checking out	5
8. Staying in your cabin	6
9. Staying in your van	7
10. The gates - getting in/out and parking	7
11. Kitchen	7
12. Water	7
13. Recycling/Rubbish	8
14. Shower rooms	8
15. Drying room	8
16. Bike wash/maintenance area/outdoor sink	8
17. BBQs and fire bowl	8
18. Pizza oven and pizza kits	9
19. Pets	9
20. CCTV	9
21. Enjoy your stay and please...	9
22. Troedyrhiw /Useful stuff nearby	10
23. Cycling to BikePark Wales	11
24. Where is the Roost?	12
25. Merthyr Tydfil	13
26. Food and Drink	14
27. Cycling	15
28. Mountain biking	16
29. Walking and hiking	17
30. Towns and villages	18
31. Other attractions and things to do	19
32. CCTV	20

---

# 1. WELCOME TO THE ROOST

---

Hello

Thanks so much for booking to stay at the Roost. Hopefully you'll find everything pretty straight forward and in this pack you'll find more info on most things. If you need anything else or have any questions then please get in touch.

We tend to leave guests to it but we'll say hello if we're about or if you need us.

We'd love to see your pics of the Roost in use so please do tag us on instagram, facebook or twitter, @roostmerthyr. Also give us a follow.

We hope you enjoy your stay and have a relaxing few days. Get in touch if you need anything.

Best wishes

Kath, Kris & the team



## 2. SUSTAINABILITY AT THE ROOST

---



Being environmentally friendly is important to us personally and we wanted to ensure that the Roost was as sustainable and environmentally friendly as possible whilst still being comfortable for our guests, all year round.

In developing the Roost, we focused on a number of key elements which we felt could lower the environmental impact of the business.

So, what do we do to make the Roost sustainable?

### > SOLAR POWER:

We're an electric only site and at the end of 2022 we installed solar panels and battery storage to help offset the site's energy usage (and growing bills). Hot water runs off an insulated hot water tank which, no matter the number of guests on site, generates and stores lovely hot water for the showers and kitchens.

### > RAINWATER HARVESTING:

We have rainwater storage tanks. The water stored is used to flush loos, wash bikes and water the garden saving a considerable amount of drinking water. If the tanks run low, our rainwater back up system switches to mains so we never run out.

### > ENERGY AND WATER EFFICIENT SHOWER ROOMS:

The shower rooms have push button showers and taps to limit water wastage and the loos have low level flushes and use rain water. The LED lights and extractor fans are on motion sensors so there are no switches and no electricity wasted. The heater also cuts out if left on. Loo roll is recycled and ordered in bulk to reduce deliveries.

### > THE KITCHENS:

They also have LED lights that are on motion sensors, no scrabbling around for light switches, and no electricity wasted either. We provide tea, coffee and sugar for guests all of which are fairtrade. Rather than disposable sponges/scourers, we provide washable scrubbies and washing up brushes with replaceable heads.

### > COSY CABINS:

The cabins are really well insulated and have LED lights and Wi-Fi controlled heaters. This means we can pop the heaters on for arriving guests, ensuring the cabins are cosy, but also turn them off when guests leave. We ask guests to be considerate in their usage of the heaters - not leaving them on with the doors/windows open, when they go out etc. Little things make a big difference.

### > OUTDOOR LIGHTS:

All our outdoor lights are on motion sensors and/or are solar powered. The pretty string lights are on a time switch so guests can turn them on. They'll stay on for about an hour and then go off so if you want them on for longer, just push the button that's between kitchen 1 and shower room 1.

#### > HOUSEKEEPING, CLEANING AND RECYCLING:

All our cleaning/laundry products, hand washes and shampoo/body washes are eco-friendly and refilled limiting our use of single use plastics and deliveries. We recycle as much as possible and encourage guests to do the same. We have separate collections for cardboard, glass, plastic and tins, and food.

Please do your bit by separating your waste/recycling and disposing of it in the correct bins.

#### > PLANTING AND WILDLIFE:

The Roost sits next to a stream and is surrounded by trees. We have planted native hedging around the perimeter of the site (800+ whips of different varieties including hazel, dog rose and hawthorn) along with lots of trees (including fruit trees). We are advocates of 'no mow' to encourage bees and insects so you won't find us strimming too often, just enough so you can still see the cabins. We have bird nesting boxes and bird feeders dotted around the site (all food is purchased from the RSPB) and a bat box.

#### > EV CHARGING:

We now have a dual EV charger so if you have an electric vehicle, you'll be able to charge it overnight.

#### > TRAIN TRAVEL:

Ok, so this isn't something we can take responsibility for but our proximity to the train station means guests don't have to travel by car. The village train station, Troedyrhiw, is a five minute walk away and connects to Cardiff, Merthyr Tydfil, Bridgend and Barry Island so why not bring your bike on the train? You can get to BikePark Wales in about 10-15 minutes by bike from the Roost, all off road. And, we're also on the Taff Trail (cycle route 8) part of which runs from Cardiff to Brecon so you could always cycle to us or stop off on the way through.

I think that's everything. If there's anything else you think we should be doing please tell us. Otherwise, we'll keep doing what we're doing to make the Roost as sustainable as we can whilst also making sure it's comfortable for guests all year round.

### 3. ROOST MAP

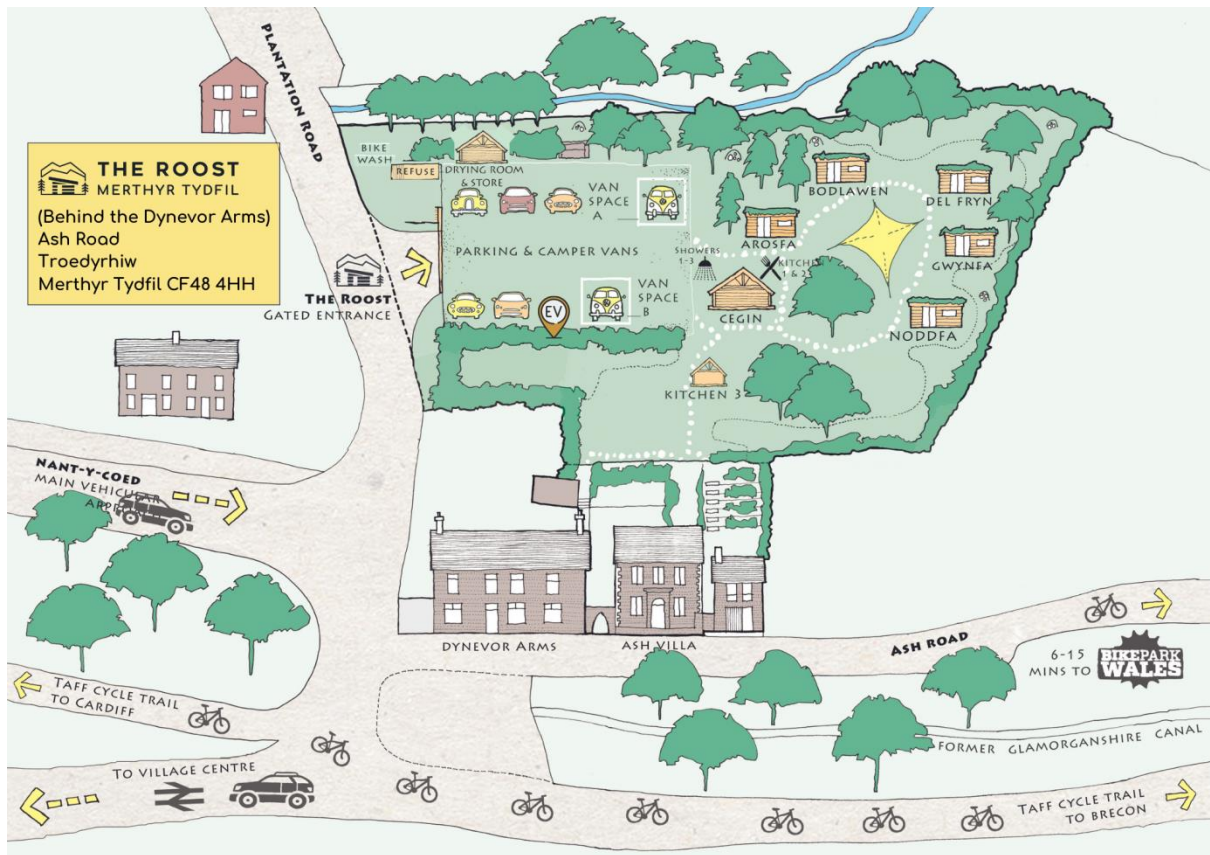

### 4. FACILITIES

Your arrival information will confirm which shower room and kitchen you have been allocated. The shower rooms and drying room require codes to enter.

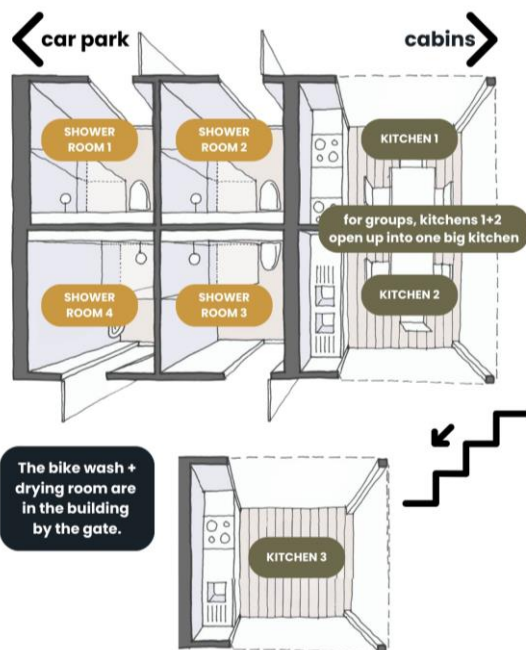

## 5. ANY PROBLEMS/IN CASE OF EMERGENCY

---

### IN CASE OF EMERGENCY CALL 999.

If you have any problems, please contact us in the first instance on 07484 697392. An alternative number is 07484 605272.

**In the event of a fire leave everything behind & get everyone out.**

- Keep calm & get everyone out quickly & safely
- Report to the assembly point by the main gate
- Alert other guests & sound the alarm - located at the fire assembly point by the main gate
- Call 999

Cabins are fitted with smoke alarms. There are fire extinguishers in each cabin and in the kitchens where there are also fire blankets.

Basic first aid kits can be found in the cabins and kitchens.

- NHS 111 can help if you have an urgent medical problem and you're not sure what to do
- A&E department - Prince Charles Hospital in Merthyr Tydfil is 24hr and has an A&E Department - Gurnos Road, Merthyr Tydfil CF47 9DT; 01685 721721
- Nearest dentist - Hapus Dental, 4 Bridge Street, Troedyrhiw CF48 4JX; 01443 692080
- Vet - RSPCA Merthyr Tydfil Clinic, The Willows, Abercanaid, Merthyr Tydfil CF48 1YF; 0300 123 0725

**Power outage:** If the power goes out, in the first instance, check the fuse box in your cabin (located in the 'porch' and, in Arosfa, by the double doors). If that's not the problem, please call us.

- An emergency torch/light is provided - when not in use, please ensure it is plugged in and switched on at the plug so that it can charge and is ready should you need it.

## 6. WiFi

---

BT Guest WiFi, no password required. This reaches most areas of the site but tends to be best around the kitchen and can be affected by the weather.

## 7. CHECKING OUT

---

**Check out by 11:00 at the latest.**

We are a small team and only have a short window to complete changeovers.

Before you leave:

- Make sure you've got all your belongings & don't leave anything behind.
  - Check the fridge, shower rooms, under the bed, drying room etc. Please don't leave food, drinks, toiletries etc.
- Empty any rubbish and recycling from the kitchen, cabin/s and shower room into the main bins (by the gate)
- Remove and bag up bedding
- Clean the bbq if used
- Turn off the cabin lights and heater
- Lock the cabin, returning the key to the key safe.

## 8. STAYING IN A CABIN

- Base sheets and mattress protectors are provided as standards, duvets and pillows with covers are an optional extra.
- Only use small appliances in the power/USB sockets or you may overload the system.
- A torch/emergency light is provided. When not in use as a torch please leave this plugged in and switched on as it will then come on in the event of a power outage.
- Touch on/off battery powered lights are provided by each bed, please don't leave these on for long periods.
- Arosfa has an ensuite shower room and kitchenette.
- Cabin heaters:
  - don't leave these on when you're out or doors/windows are open
  - please think about your usage too as electricity is v expensive
  - guests currently have full control over the heaters but excessive use may result in us restricting this.

# USING THE HEATER

Adjust the temperature and switch the heater on/off using the panel on the front

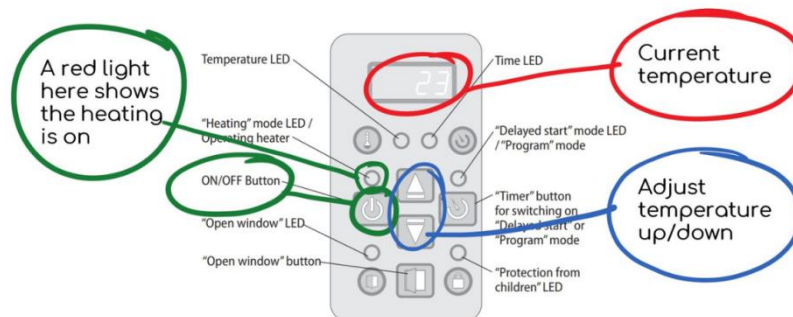

- ✓ Please turn the heater off before you go out for the day/leave.
- ✓ Keep the temp below 23°C. The cabins heat up quickly if the windows/doors are closed. Its ok to leave them on a low temp overnight (12°C should keep things cosy).
- ✗ Please don't put anything on/over the heater, especially wet things (use the drying room). It's an electric heater so this is very dangerous.



## 9. STAYING IN YOUR VAN

---

- As a campervan guest, you will have been allocated a kitchen and shower room
- Please park your van in the booked space next to the sign/hook-up:
  - pitch A is on the left hand side by the trees
  - pitch B is on the right hand side at the rear of the kitchen/shower block
- Please be considerate to other guests when parking
- Electric hook-ups are provided subject to a fair use policy and we reserve the right to request payment for excessive use.

## 10. THE GATES - GETTING IN/OUT OF THE ROOST + PARKING

---

- **Getting in/out by car** – enter code 1 (the main gate code) as per your arrival info email. To exit by car, enter the same code you used to get in (code 1); the keypad is just to the right of the main gate, on the side gate (we want to stop unwanted visitors leaving the site without a code).
- **Getting in/out on foot or by bike** – to open the side gate from either side, enter code 2 as per your arrival information email
- Please park facing the big rocks on the right hand side and be considerate to other guests when parking

**Dual EV charger** – this is available for guests to use and we will have/can send you all the information you need to do this. Please contact us for information.

## 11. THE KITCHENS

---

Your arrival information email will confirm which kitchen you have been allocated (the plan on p5 shows the locations of the kitchens). Please only use the kitchen allocated to you.

Each kitchen has a sink, fridge, microwave, kettle, toaster, two ring hob and a variety of cooking equipment/utensils plus crockery/cutlery.

- Please wipe round and empty the fridge/bins before you leave. Don't leave unwanted food, drink etc.
- Make sure you turn the hob rings off; they quite often get left on.
- BBQs and BBQ tools are provided, you will need to use your own charcoal and clean it when finished.

For groups, the wall between kitchen 1+2 can be rolled up to make a large kitchen. The outer walls of the kitchens can also be left open for ventilation. They can also be rolled up carefully.

## 12. WATER

---

The water in the kitchens and shower rooms is drinking water.

The water from the outside taps/hose/bike wash is **NOT** suitable for drinking as they use rainwater from our rainwater storage tanks. The loos flush with rainwater when we get it so it might look a funny colour.

Please don't waste water. The rainwater tanks can sometimes run dry (it doesn't rain as much as you might think) so please only use what you need when washing your bikes.

## 13. RECYCLING + RUBBISH

---

We are trying to make the Roost as sustainable as possible and would appreciate your help with this. The recycling/rubbish bins are split as follows:

- **General waste** – non recyclable stuff
- **Recycling** – cardboard, glass, metal cans and plastic
- **Food waste** – please use the small compost caddy bin.

The main bins are situated by the side gate.

Please put your recycling in to the relevant bins. We quite often have to sift through the rubbish/recycling due to some guests putting stuff in the wrong bins as the council won't take it. Not a nice job.

## 14. SHOWER ROOMS

---

You will be allocated a shower room (see plan p5). They are located on either side of the kitchen.

- You need a code to access your shower room; this is in your arrival info email.
- The light and fan will go on/off automatically, turn the heater on/off using the cord.
- The loos flush with rainwater so the water can sometimes look a funny colour.
- We provide handwash, hand towels, toilet roll, a bath mat and anti bac spray.
- Please dispose of sanitary waste in the paper bags provided and then into the bin.
- Don't flush anything other than loo paper.
- We will clean the shower rooms prior to arrival but not during your stay.

## 15. DRYING ROOM + WASHING LINES

---

There is a small, shared drying room. Instructions on how to use this are on the wall in the drying room.

There are also washing lines and pegs. Please don't dry anything on the cabin heaters as this is a fire risk.

## 16. BIKE WASH + MAINTENANCE AREA

---

Behind the side gate and the rubbish/recycling area, there is a bike wash area with clamp and brush. Please try not to waste water.

## 17. BBQs + FIRE BOWL

---

There is a shared fire bowl with seating. You can bring your own kiln dried wood or buy from us. Empty the ash into the bucket provided. Fires are not allowed anywhere else on the site.

There are a number of BBQs dotted about. Please feel free to use these. You'll need to bring your own charcoal, clean after use and put the cover back on.

Please be careful, especially in the summer, when things can be very dry.

## 18. PIZZA OVEN + PIZZA KITS

---

We now have a wood fired pizza oven. Please see the back rear of this info pack for more information on how to use the oven etc.

We are working on pizza kits so they are hopefully coming soon.

## 19. PETS

---

Well behaved pets/dogs are welcome so long as you clean up after them and they don't disturb other guests.

- There is a poo bin just outside the Roost; turn left out of the gate and the bin is to the right of the car park in front of the pub. There are poo bags on the fence by the facilities block.
- Please keep dogs off the beds
- Guests will be charged for any excessive cleaning or damage caused.

## 20. CCTV

---

We operate external CCTV systems which are recording on a continual basis. Images are stored in a secure system and under usual operational circumstances deleted after a period of one month.

The CCTV systems are provided as a service, and with our guests and their property in mind. Signage is in place to remind guests that CCTV systems are in operation. We use a qualified and reputable CCTV partner to maintain our systems.

## 21. FINALLY, ENJOY YOUR STAY AND PLEASE...

---

Be considerate to other guests and the Roost's neighbours:

- Keep the noise right down between 22:00 and 07:30. We're a small site with neighbours and noise carries. If you're leaving early, please do so quietly.
- No smoking or vaping in or around the cabins or shared areas. The smoke gets into the cabins easily but it's not so easy to get the smell out. Please only smoke/vape in the car park where there is an ashtray/bucket (by the fire meeting point).
- Please dismount your bike in the car park and walk it through the site. Also give your bike a wash before storing it in your cabin.
- Tell us about any breakages, missing items or things not working so that we can replace/fix.

## 22. TROEDYRHIW + USEFUL STUFF NEARBY

The name of the village, Troed-y-rhiw, means 'foot of the slope' in Welsh and the Roost is located on a hill at the top of the village.

Troedyrhiw has a rich industrial heritage linked to the extraction of coal and iron ore in the 19 century. Built in c1830, Ash Villa (the house adjoining the Roost), and the neighbouring Dynevor Arms public house, originally formed part of a terrace of cottages facing the historic Glamorganshire canal which was used for transporting industrial goods from the Valleys to Cardiff docks.

The village centre is a five minute walk away (the quickest route is to walk down Ash Road, see green arrows below). Here you'll find pubs, two well-stocked shops, chemist, cashpoint (within the Londis), an Indian restaurant/takeaway ([Simply Indian](#)) and various takeaways.

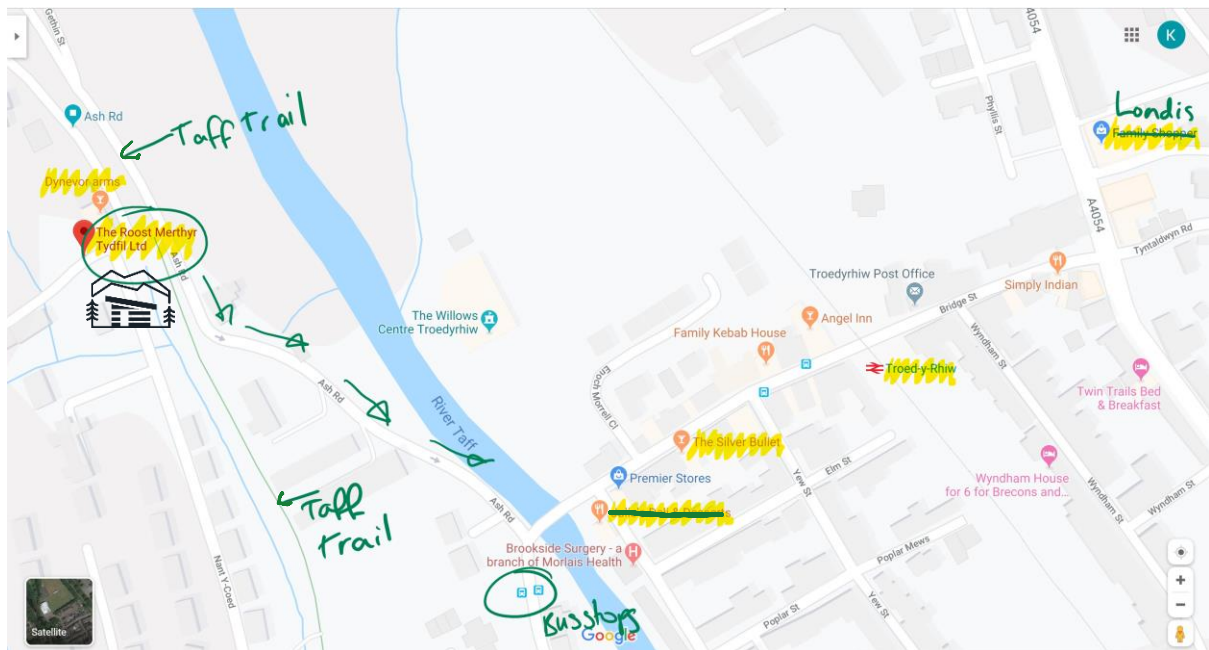

The Dynevor Arms next door sometimes does food, shows the football and has a pool table. The Silver Bullet in the village also does food.

Troedyrhiw train station, a 5 minute walk away, connects directly to Merthyr Tydfil, Bridgend, Barry Island and Cardiff.

Merthyr Tydfil town centre can be reached by car (12 minutes); train from Troedyrhiw station (10 minutes) or bike (20 minutes on the Taff Trail). Here you'll find a wider choice of food and drink and shopping, a cinema and leisure centre.

There's a larger Co-op supermarket in Pentrebach (7 minutes by car, 10 minutes by bike) along with a Halfords. In Merthyr Tydfil you'll also find a Tesco Extra, Aldi and M&S.

Petrol station: Applegreen Merthyr Tydfil, CF47 8EB (opposite Aldi).

Taxis: Ran's Cabs 01685 377777, Spencer's Taxis 07903 354164/07932 829384

Buses run from Glantaff Road, at the bottom of Ash Road. They run to Merthyr Tydfil and the surrounds - [bustimes.org/localities/troedyrhiw-merthyr-tydfil](http://bustimes.org/localities/troedyrhiw-merthyr-tydfil).

## 23. CYCLING TO BIKEPARK WALES

---

BikePark Wales is 1.1 miles from the Roost, as the crow flies.

By car, its three miles and approximately 10 min away.

There are a few bike route options, off road.

[Check out our video of how to get to BPW by bike.](#)

### 1. Via Ash Road – 15 min, 1.3 miles (7 min on the way back...)

*Fyi, there's a footbridge with quite a few steps that you'll need to carry your bike up*

- With the Dynevor Arms behind you, turn left and carry on up Ash Road (past the houses next to the pub not along the Taff Trail)
- Ash Road turns into a lane/path, follow this to a footbridge
- Go up and over the footbridge
- On the other side of the bridge turn right and follow the path/lane
- The lane comes out by the roundabout on the A470 that leads up to BPW
- Follow the main route up to BPW.

### 2. Via the Taff Trail and Webbers Pond

- With the Dynevor Arms behind you, go left on to the Taff Trail (Gethin Street/National Cycle Route 8), not the lane past the houses next to the pub
- Follow the Taff Trail until you cycle underneath the A470
- Turn left on the other side of the bridge, following a loops and links trail



- Follow the trail up and to the right
- Take a left through an underpass (under the A470)
- The path bears left & follow to BPW
- You will (should!) come out on the road up to BPW.
- [Watch our video of how to get to BPW by bike.](#)

## 24. WHERE IS THE ROOST?

The Roost is situated in the village of Troedyrhiw on the outskirts of Merthyr Tydfil in the South Wales Valleys and on the edge of the Brecon Beacons. We've got some of Wales' best hiking and biking on our doorstep plus lots of other stuff too.

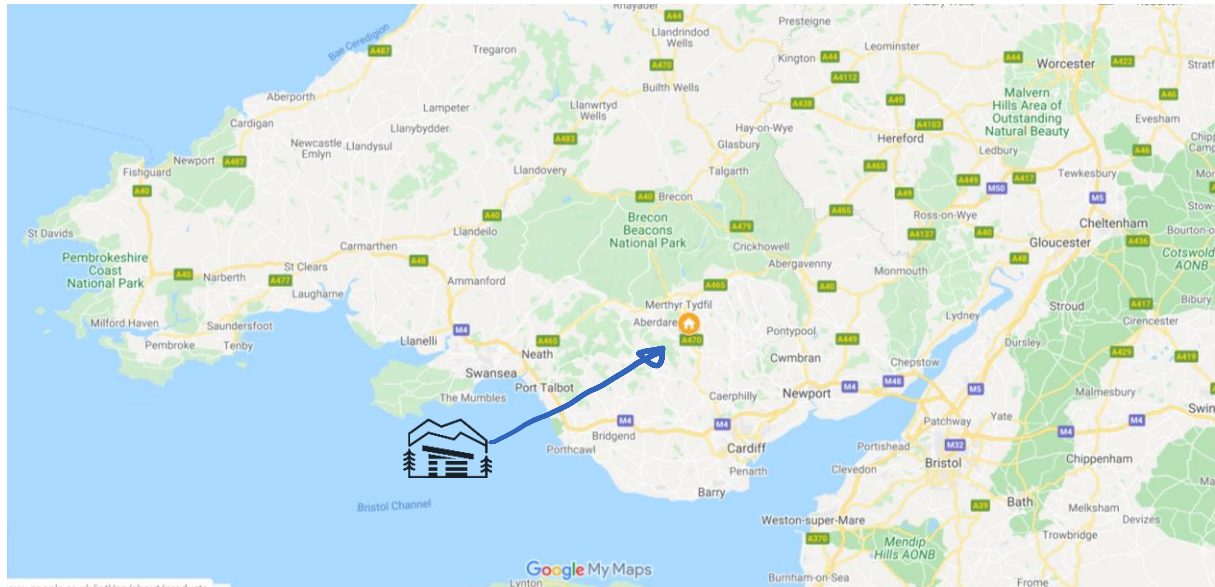

	As the crow flies...	Drive time (approx.)
Merthyr Tydfil	5 miles	11 min
Crickhowell	14 miles	34 min
Abergavenny	16 miles	35-45 min
Brecon	16 miles	35-45 min
Cardiff	17.5 miles	35-45 min

For more information and ideas, visit:

- On the Roost's website, there's an interactive map with various things to do, see and eat - [roostmerthyr.co.uk/things-to-do](http://roostmerthyr.co.uk/things-to-do)
- [www.visitwales.com](http://www.visitwales.com)
- [www.visitmerthyr.co.uk](http://www.visitmerthyr.co.uk)
- [www.breconbeacons.org](http://www.breconbeacons.org)
- [www.southernwales.com](http://www.southernwales.com)
- [www.mbwaales.com](http://www.mbwaales.com)

## 25. MERTHYR TDFIL

---

Merthyr Tydfil town centre can be reached by car (12 minutes); train from Troedyrhiw station (18 minutes) or bike (20 minutes on the Taff Trail). Here you'll find a wider choice of food and drink and shopping, a cinema and leisure centre. There's plenty to do and see, including:



### Cyfartha Park & Castle

Visit the castle (built for the ironmaster William Crawshay II in 1824/5) and museum and explore the extensive grounds (woodland walks and nature rambles, stunning views and a splash pad and playground). There's also a miniature railway and tea rooms.

© [wellbeingmerthyr.co.uk](http://wellbeingmerthyr.co.uk)

© CF47 8PA



### Brecon Mountain Railway

Travel by steam train into Brecon Beacons National Park, through Pontsticill and along the Taf Fechan Reservoir before climbing to Torpantau high in the Brecon Beacons and the summit of the original line. Walk around the reservoir, visit the café or tea rooms and take in the breath taking views.

© [www.bmr.wales](http://www.bmr.wales)

© CF48 2DD



### Parc Taf Bargoed

Situated in the beautiful Taff Bargoed Valley, Parc Taf Bargoed is deemed by many as being the hidden gem of Merthyr Tydfil with its panoramic views and natural beauty. The park, formerly the site of three collieries (Trelewis Drift, Deep Navigation and Taff Merthyr), cover an area of 140 hectares and was the subject of an ambitious land reclamation scheme which transformed the site.

© CF46 6AP

For more information have a look at the Visit Merthyr guidebook (there should be one in the cabin) or explore Visit Merthyr's online interactive map:

[www.visitmerthyr.co.uk/map-page](http://www.visitmerthyr.co.uk/map-page)

[www.visitmerthyr.co.uk/things-to-do/trails-walking-cycling/](http://www.visitmerthyr.co.uk/things-to-do/trails-walking-cycling/)



## 26. FOOD AND DRINK

---

In Troedyrhiw, within walking distance of the Roost (see map p3)...

- Dynevor Arms, next door to the Roost – drinks & pool tables
- New Simply Indian – restaurant/takeaway/delivery
- Pak-Ho – Chinese takeaway
- Ying Wah – Chinese takeaway
- 2 x pizza & kebab takeaways
- 2 x Premier stores – groceries, bakery
- Llwyn Yr Eos Inn – on the Taff Trail, a 15min walk from the Roost

In Merthyr Tydfil (booking is recommended, particularly at weekends):

- New Crown Inn – drinks, food, tea/coffee/cake, live music
- Portugalles – Portuguese restaurant
- [Casa Bianca](#) – Italian restaurant
- [The Mine & Castelany's](#) – Italian, pizza, street food, meat...
- [Mango House](#) – Indian & Bengali cuisine. Popular & booking essential at weekends.

There are lots more options including fish & chips, Dominos, Papa Johns, Nandos, Pizza Hut etc.

[Just Eat](#) has lots of delivery options too.

Further afield - here are just a few options:

- **Bunch of Grapes, Pontypridd**  
Nice pub with good food and beer selection. Can be cycled to on Taff Trail. Dogs welcome in the bar. Worth booking on weekend.  
[www.bunchofgrapes.org.uk](http://www.bunchofgrapes.org.uk)
- **The Aberglais**  
Located next to the Ponsarn Viaduct so a good spot/stop off for walks. Beer garden, food and drinks. Dogs welcome.  
[www.facebook.com/TheAberglaisPonstarn](https://www.facebook.com/TheAberglaisPonstarn)
- **Red Cow Inn**  
Pontsticill. Roaring fires, hearty food and decent beer selection. Dogs welcome.  
[www.facebook.com/redcow01685387775/](https://www.facebook.com/redcow01685387775/)
- **Nant Ddu Lodge**  
On the road to Brecon. Bar, restaurant, spa with garden. Afternoon tea, Sunday lunch, bar/restaurant menu. Dogs ok in garden.  
[nant-ddu-lodge.co.uk/dining](http://nant-ddu-lodge.co.uk/dining)
- **The Star Inn**  
Friendly pub next to the canal/river in Talybont on Usk. Great beer selection, big beer garden. Does food. Dog friendly.  
[www.facebook.com/thestartalybont](https://www.facebook.com/thestartalybont)
- **Old Barn Tea Rooms**  
On the cycle route to Talybont so a good pit stop for a reviving scone or sandwich.  
[www.facebook.com/people/The-Old-Barn-Tea-Rooms-Ponsticill](https://www.facebook.com/people/The-Old-Barn-Tea-Rooms-Ponsticill)





## 27.CYCLING

---



### Taff Trail – part of cycle route 8

A 55 mile route from Cardiff to Brecon along a mix of riverside paths, railway paths and forest roads. It runs just outside the Roost providing easy flat access to Merthyr Tydfil. The route up in to the Brecon Beacons is a little more hilly! Stunning stuff. If you cycle to Cardiff you could always get the train back to Troedyrhiw station.

© [www.sustrans.org.uk/find-a-route-on-the-national-cycle-network/taff-trail-cardiff-to-brecon](http://www.sustrans.org.uk/find-a-route-on-the-national-cycle-network/taff-trail-cardiff-to-brecon)



### The Three Peaks

A challenging 38 mile route taking in three peaks – the Bloreng, the Skirrid and Sugar Loaf. Stunning views with big climbs. Starts and finishes in Abergavenny.

© [www.cyclinguk.org/favourite-ride-abergavenny-three-peaks](http://www.cyclinguk.org/favourite-ride-abergavenny-three-peaks)

For more routes and cycling options, visit:

[www.sustrans.org.uk](http://www.sustrans.org.uk)







[www.cyclinguk.org/routes](http://www.cyclinguk.org/routes)

[www.visitmerthyr.co.uk/things-to-do/trails-walking-cycling](http://www.visitmerthyr.co.uk/things-to-do/trails-walking-cycling)



## 28. MOUNTAIN BIKING

There are plenty of options for mountain biking in this area. Whether you're looking for trail centres or a bit of off roading, here are a few options:



	<p><b>BikePark Wales</b> Offers a variety pack of trails of varying grades plus a café, facilities and bike hire. Just over a mile away by bike, off road, or 10 minutes by car (route details included in this pack).            ☉ <a href="http://www.bikeparkwales.com">www.bikeparkwales.com</a>            ☉ CF48 4TT</p>
	<p><b>Cwmcarn Forest</b> Cwmcarn has two red graded 'difficult' trails and one 'extreme' trail. Trails are free to ride and open all year. 35 minutes by car from the Roost.            ☉ <a href="http://www.cwmcarnforest.co.uk/activities/mountain-biking-at-cwmcarn">www.cwmcarnforest.co.uk/activities/mountain-biking-at-cwmcarn</a>            ☉ NP11 7FA</p>
	<p><b>Dirt Farm</b> Mountain biking in the breath taking Black Mountains. 40 minutes by car from the Roost.            ☉ <a href="https://dirtfarm.wales/">https://dirtfarm.wales/</a>            ☉ NP7 7PE</p>
	<p><b>Afan Forest Park</b> Six world class trails and over 130km of single track trails. The Afan Bike Park allows riders to improve their riding skills and have 'hours of winding, swerving fun with berms and jumps'. Bike hire, café, showers etc. Also walking trails. 50 minutes by car from the Roost.            ☉ <a href="http://www.afanforestpark.co.uk">www.afanforestpark.co.uk</a>            ☉ SA13 3HG</p>
	<p><b>Sarn Helen and Fforest Fawr</b> A blue grade loop, approx. 13km. Roman roads, forests, waterfalls and big views.            ☉ <a href="http://ridewithgps.com/routes/2137424">ridewithgps.com/routes/2137424</a>            ☉ CF44 9JF</p>
	<p><b>The Gap</b> A classic. A red grade route taking in the Brecon Canal, Taff Trail, <a href="#">Brinmore Tramway</a> and the Gap Road. 35km. Hilly in parts with awesome scenery. Refreshments in Talybont on Usk. Can be cycled directly from the Roost.            ☉ <a href="http://www.mbwales.com/listings/the-gap">www.mbwales.com/listings/the-gap</a></p>

For more information and ideas, visit [www.mbwales.com](http://www.mbwales.com)

## 29. WALKING AND HIKING

You're spoilt for choice for walks and hikes in and around the Valleys and the Brecon Beacon National Park. There are some famous, well-trodden routes up Pen-y-Fan and the Four Waterfalls walk but there are lots more too. Whether you're looking to hike or for something more gentle, here are a few options.

Here are a few:

	<p><b>Taf Fechan</b> A circular walk from Cyfartha Park in Merthyr Tydfil that's pretty easy going. The route runs along the Cyfartha Leat, the old Gurnos Tramway and the Taf Fechan river. It's a stunning walk up to the Pontsarn Viaduct (detour to the Aberglais Inn for refreshments/food). There are a few variations: © 5 miles - <a href="http://www.beacons-npa.gov.uk/wp-content/uploads/3.-Taf-Fechan-FINAL.pdf">www.beacons-npa.gov.uk/wp-content/uploads/3.-Taf-Fechan-FINAL.pdf</a> © 7.5 miles - <a href="http://downloads.bbc.co.uk/tv/weatherman-walking/walks/Merthyr.pdf">downloads.bbc.co.uk/tv/weatherman-walking/walks/Merthyr.pdf</a></p>
	<p><b>Blaen y Glyn walk</b> A stunning walk with a steep ascent and descent towards the end. It's got a bit of everything – forest, moorland, numerous waterfalls and pools (perfect for cooling off), sheep, ponies, wild flowers and stunning views. Approximately 5 miles. Start at the forestry car park at Blaen y Glyn Uchaf, it can get busy. © LD3 7YT © <a href="http://thefocus.wales/2012/03/blaen-y-glyn-walk/">thefocus.wales/2012/03/blaen-y-glyn-walk/</a></p>
	<p><b>Cribyn</b> Not quite as high as Pen y Fan but well worth doing. 11.5 miles, approx. 6 hours. Moderate/challenging © <a href="http://www.countryfile.com/go-outdoors/days-out/day-out-cribyn-powys">www.countryfile.com/go-outdoors/days-out/day-out-cribyn-powys</a></p>

There are too many walks to document so here are some useful links:

- The Brecon Beacons National Park Visitor Centre is a great place to start lots of walks. It's got an information centre, café and shop - [www.breconbeacons.org/business/attraction-brecon-beacons-national-park-visitor-centre](http://www.breconbeacons.org/business/attraction-brecon-beacons-national-park-visitor-centre)
- [www.breconbeacons.org/things-to-do/walking/routes](http://www.breconbeacons.org/things-to-do/walking/routes)
- [www.countryfile.com/go-outdoors/walks/best-walks-in-the-brecon-beacons](http://www.countryfile.com/go-outdoors/walks/best-walks-in-the-brecon-beacons)
- BBC Wales' walking weatherman, Derek Brockway, has documented some lovely walks throughout Wales. To find them, search for 'weatherman walking' or use the link below: [www.bbc.co.uk/programmes/articles/4r0gdLJc3Hnm7t0k2cD3ZP4/maps-and-route-information](http://www.bbc.co.uk/programmes/articles/4r0gdLJc3Hnm7t0k2cD3ZP4/maps-and-route-information)
- [www.visitmerthyr.co.uk/things-to-do/trails-walking-cycling](http://www.visitmerthyr.co.uk/things-to-do/trails-walking-cycling)

### The Taff Trail

The Roost sits on the Taff Trail, a popular 55-mile long-distance cycling and walking route. It follows the River Taff, running from Cardiff to/from Brecon.

[Read our blog post](#) about the Taff Trail. It includes links to walks, rides and food stops along the way.

## 30. TOWNS AND VILLAGES

---



### Abergavenny / Y Fenni

This market town is famous for its food and cycling festivals. It's surrounded by stunning mountains - the Bloreng, the Sugar Loaf and the Skirrid, all of which are worth walking/cycling. There's a castle, canal walks and independent shops. The bar at the Angel Hotel is very cosy and does good food. Lots of other pubs and places to eat.

© [www.visitabergavenny.co.uk](http://www.visitabergavenny.co.uk)



### Brecon / Aberhonddu

An historic market town on the Monmouthshire and Brecon Canal, in the heart of the national park. Famous for its jazz festival. There's another castle, walks galore on the doorstep and it's at the end (beginning?) of the Taff Trail. Try the Brecon Tap for brilliant beer and pies.

© [brecontowncouncil.org.uk](http://brecontowncouncil.org.uk)



### Cardiff / Caerdydd

The Welsh capital. There's a lot to see and do and it is well worth a visit. You can get the train there from Troedyrhiw in approximately 50 minutes. Alternatively you can drive there or cycle there on the Taff Trail (maybe get the train back).

© [www.visitcardiff.com](http://www.visitcardiff.com)



### Crickhowell / Crughywel

Picturesque Crickhowell has a castle, walks and cosy pubs. It's fiercely independent (no big chains here). There's an annual walking festival and the Green Man festival. Try the café in Book-ish for lunch and The Bear for cosy pub food.

© [www.visitcrickhowell.co.uk](http://www.visitcrickhowell.co.uk)



### Hay on Wye

A small town famous for its book festival and books - it has many second hand book shops, arts and craft and independent shops. Lots of cafes and restaurants too.

© [www.hay-on-wye.co.uk](http://www.hay-on-wye.co.uk)

## 31. OTHER ATTRACTIONS AND THINGS TO DO

---

### Big Pit National Coal Museum

Explore South Wales' history of coal at this real coal mine (1880-1980) that offers underground tours, miner guides and an insight into what it would have been like to work in a mine.

☉ [museum.wales/bigpit](http://museum.wales/bigpit)

### Dan-yr-Ogof - National Showcaves Centre for Wales

Explore the caves, see the dinosaurs and visit the iron age village and museum. There's a play centre and coffee shop. A great rainy day option.

☉ [www.showcaves.co.uk](http://www.showcaves.co.uk)

### Gower Peninsula

A stunning coast path and beautiful beaches - Langland, Caswell, Three Cliffs, Oxwich etc.

☉ [www.visitswanseabay.com/destinations/gower-peninsula](http://www.visitswanseabay.com/destinations/gower-peninsula)

### Horse riding/trekking

There are a few riding centres in and around the Beacons including:

☉ [www.ellesmereridingcentre.co.uk](http://www.ellesmereridingcentre.co.uk)

☉ [www.cantref.com](http://www.cantref.com)

### Parkwood Outdoors Dolygaer

An activity centre near Merthyr Tydfil with activities for all ages – sailing, rock climbing, hiking, kayaking and more.

☉ [www.parkwoodoutdoors.co.uk/centre/dolygaer](http://www.parkwoodoutdoors.co.uk/centre/dolygaer)

### Penderyn Distillery

The only whiskey distillery in Wales. Take a tour and sample the whiskey and other spirits.

☉ [penderyn.wales](http://penderyn.wales)

### Rock climbing at Rock UK's Summit Centre

The Summit Centre has some of the highest climbing walls in South Wales. Suitable for all ages and abilities. Also has a café and outdoor play centre.

☉ [rockuk.org/centres/summit-centre](http://rockuk.org/centres/summit-centre)

### St Fagan's National Museum of History

Explore the history of Wales. There's a living museum, castle and beautiful gardens, exhibitions, activities and more. It's free and well worth a visit.

☉ [museum.wales/stfagans](http://museum.wales/stfagans)

### Watersports

Sailing, canoeing, kayaking, windsurfing, canal boating...

☉ [www.breconbeacons.org/things-to-do/activities/watersports](http://www.breconbeacons.org/things-to-do/activities/watersports)

### Zip World – Tower

Home to Phoenix, the world's fastest seated zip line, with 4 parallel lines in 2 separate zip zones and the Tower Coaster, the only one of its kind in Europe, boasting a side-by-side kart, making it possible for two people to ride at once.

☉ [www.zipworld.co.uk/location/tower](http://www.zipworld.co.uk/location/tower)

